

Crane lifting eye optional
Article number: 911011005

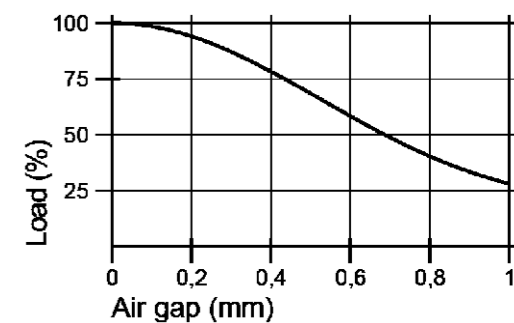
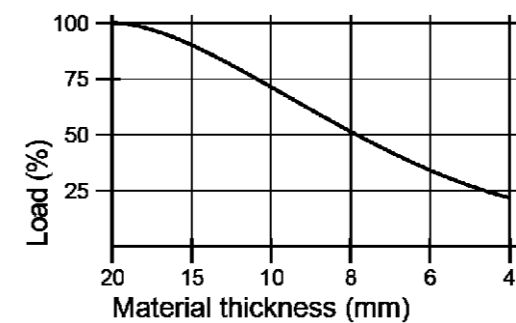
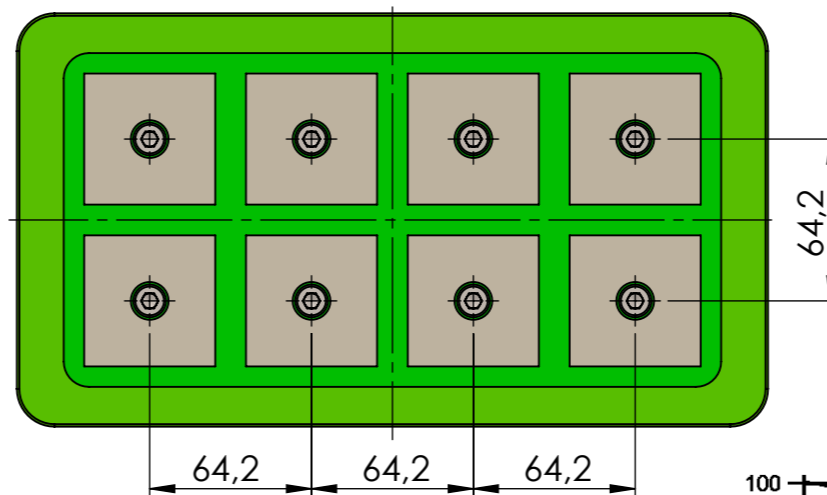
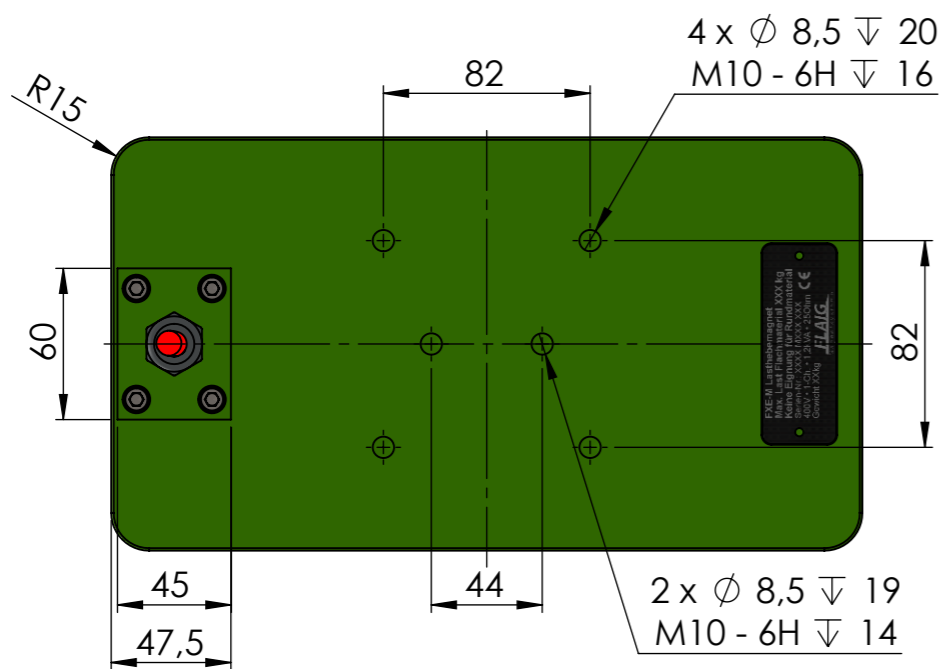
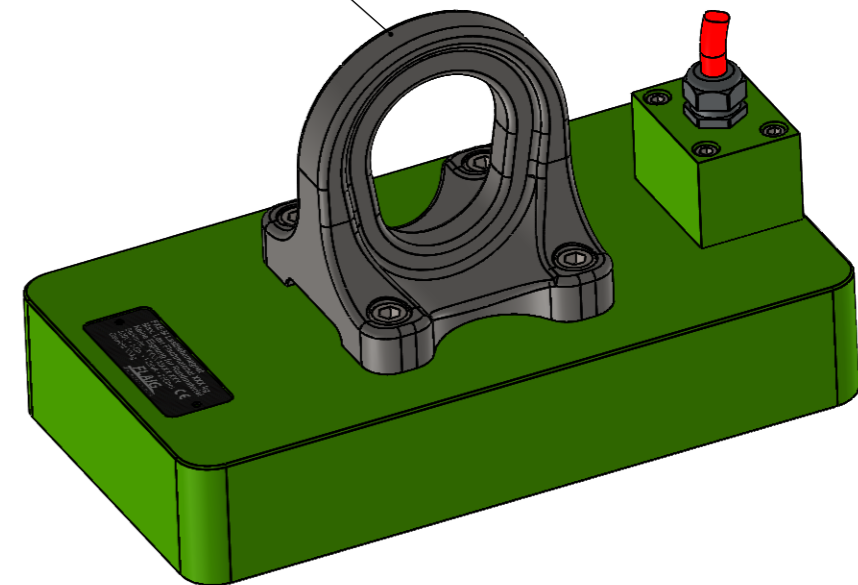

Specification FXE-M 750-50

Nominative Force: 30,4kN	lifting capacity EN 13155/WLL
Materialthickness >15mm (100%)	750kg
2,2kVA	
U: 380-480V Pulse	Protection Type IP 65
R: 12,6Ω	Protection category SK I

Schutzvermerk nach DIN ISO 16016 beachten!
Nachdruck nur mit unserer Genehmigung!
All rights reserved according to DIN ISO 16016!
Reprint with our permission only!

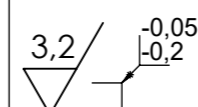

Zul. Abw.	
ISO 7168 M	
Datum	Name
Erstellt 15.02.2021	MF
Gepr.	
Freig. 12.05.2022	TW

Material:		Gewicht: 20.00 kg	
Zeichnungsnummer:		0012960	
Benennung:		FXE M 750-50	
Artikelnummer:		10610701	
Blatt 1 / 1		A3	
Maßstab: 1:3		Status: Freigegeben	



Rev.	Änderung	Datum	Name
------	----------	-------	------